

Simulating human behavior in macroeconomic
models applied to climate change

Klaus Hasselmann
Max Planck Institute for Meteorology and European Climate Forum
file:Dahlem.tex

September 26, 2008

1 Introduction

With the widespread acceptance of the reality of climate change, scientists need to urgently develop realistic models of the coupled climate-socioeconomic system in support of policymakers striving to implement effective climate policies. Since the evolution of the global socio-economic system is governed by the actions of many different human actors, this forces one to address the "Mathematics of Social Entities". More important than formal mathematical analysis in this context, however, is the development of numerical models, with which the behavioral hypotheses of social scientists can be translated into quantifiable computer simulations.

The focus of traditional climate research has been on understanding the complex network of linear and nonlinear interactions that govern the dynamics of the coupled physical, chemical and biological components of the climate system. The need to interact with other disciplines to consider the interactions within the full earth system, including the so-called anthroposphere, now presents scientists with the new challenge of combining the "soft" social and "hard" natural sciences.

A basic difficulty of this task is that global climate change, although undoubtedly the most serious long-term threat to the very existence of human civilization as we know it today, cannot be considered in isolation from the many other stresses and tensions attending the rapid globalization of the socio-economic system, such as wide-spread poverty, growing rich-poor inequalities, migration pressures, and increasing conflict potential, from terrorism to regional conflicts to international confrontation. Shorter term processes, such as business cycles, recessions and financial instabilities, which are normally ignored in macroeconomic models of longer term economic growth, must also be considered, since policymakers need to continually balance short and long term impacts in their policy decisions.

Taken literally, this implies that a meaningful coupled climate-socio-economic model needs to encompass a daunting array of interrelated global and regional

problems - representing, in effect, the evolution of the entire human civilization and the global ecological system on which it depends. Clearly, this is an unrealistic goal. In fact, ambitious models of the evolution of human civilization and attempts to translate such models into policies for enhancing human happiness have a rather mixed – not to say disastrous – historical track record. But the question can nevertheless be posed: can the the investigation of a few critical sub-problems and an examination of their relation to the general problem of societal evolution contribute to a more realistic integrated "world view"? And the corollary, in accordance with the theme of this symposium, is then: "Can mathematics assist in this endeavor?"

Before entering into a more detailed discussion, a few self-evident observations may be appropriate:

1) A basic difference between social and natural systems is that there exist no universally accepted rules of human behavior, whereas natural systems can be described by universal laws (even though the detailed evolution of complex natural systems cannot necessarily be deduced from such laws due to excessive computational requirements or the chaotic nature of complex systems). Models of coupled social and natural systems are therefore unable to provide universally valid conclusions, but are inherently limited to an analysis of the implications of hypotheses regarding human behavior. Nevertheless, the translation of such hypotheses into quantifiable mathematical relations are usually a prerequisite for a better understanding of the hypotheses. This applies particularly to complex systems involving interactions between several actors, a typical characteristic of socio-economic models relevant for climate policy.

2) If the ultimate goal is to obtain a balanced understanding of the dynamics of the complete coupled climate-socio-economic system, it is clearly not meaningful describe one particular component of the earth system - for example, the global climate system - in excessive detail at the cost of other critical components - such as the basic conflict between the need for international cooperation in climate policy and the international competition characterizing the present global free-market system. In the case of climate models, several reduced-complexity models have been developed (e.g. Hoos et al, 2003, IPCC 2008, WG 1, Ch 8.8) which capture the dominant response characteristics of the climate system to external forcing with minimal (lap-

top) computational requirements. However, there exist only few analagous reduced socio-economic models (e.g. de Vries, 1998, Weber et al, 2005) that focus on the multi-actor processes relevant for climate policy assessment.

3) There is a natural limit to the complexity that a meaningful multi-actor model of the coupled climate-socio-economic system can attain. This is given on the one hand by the limitations of the available data for testing the behavioral hypotheses and, on the other hand, by the difficulty of distinguishing between competing hypotheses if the model contains too many adjustable parameters. The latter restriction holds also for qualitative expository models. To ensure that one remains within these limitations, it is useful to develop models in the form of a model hierarchy, beginning with the simplest model at the lowest level, and successively introducing more processes until one reaches a level of complexity that can no longer be justified by the data or the number of model parameters.

4) Social and natural scientists need to overcome language difficulties arising from their different educational backgrounds. Natural scientists, in particular physicists familiar with differential equations, tend to work in the conceptual framework of system dynamics. Although these concepts are being adopted in many areas of economics, such as business dynamics (cf. Sterman, 2005), they has not yet penetrated the field of macroeconomical modeling of climate change. To communicate effectively, the dynamic systems concepts developed by natural scientists need to be expressed in a language understandable to traditional economists less familiar with systems of coupled nonlinear ordinary differential equations. Fortunately, there exist various modern software platforms (e.g. Vensim, Stella) that present the mathematical interdependencies in generally understandable graphical form.

To understand the origins of the deficits in modeling human behaviour in relation to climate change and identify possible ways forward, it is useful to review briefly the tide of paradigm change that is currently sweeping through economic thinking (see, for example, Colander, 2006, and Beinhocker, 2008)

2 The paradigm shift in macroeconomic theory

From the simplified viewpoint of a climate physicist, traditional macroeconomics has been built on two principal pillars: mental models and formal mathematical analysis. Our present understanding of how the economy works is still strongly anchored in the mental models developed by a formidable succession of classical economic thinkers, from Francois Quesnay, Adam Smith, David Ricardo, Karl Marx, John Maynard Keynes and Joseph Schumpeter to Milton Friedman, to name but a few. Attempts to underlay or extend these concepts, beyond explanatory graphs, with rigorous mathematical analysis, beginning in the late 19th century, led to an equally impressive array of theoretical constructs, including general economic equilibrium theory - still the central concept of traditional mathematical macroeconomics today -, econometrics and statistical inference, the theory of economic growth, and game theory. However, it has always been recognized that the enormously complex macroeconomic system, governed by the multiple interactions of innumerable, notoriously unpredictable human agents, can be made amenable to formal mathematical analysis only by introducing highly restrictive simplifications. Thus the relation between the mental models of the classical economists and formal mathematical analysis has always been tenuous and controversial.

With the advent of increasingly powerful computers, however, many of the technical difficulties restricting the application of formal mathematical analysis could be simply side-stepped by direct computer simulation. This has motivated a plethora of new approaches. Most of these fall within the general class of multi-agent simulations, referred to variously as agent-based computational economics (ACE, Tesfatsion, 2006), multi-agent systems (MAS, Epstein and Axtell, 1996, Axtell, 2006), or, in a more general context, evolutionary economics (Nelson and Winter, 1982), complexity economics (Beinhocker, 2006), post-Walrasian economics (Colander, 2006) or simply system dynamics (Sterman, 2000).

The common goal of most of these approaches is to derive the characteristic features of macroeconomic systems as "emergent properties" of microeconomic systems governed by the interactions between (typically a large number of) individual agents. The simulations have been successful in explaining

many of the interesting and often puzzling features of macroeconomic systems, such as the large volatilities, non-Gaussian fluctuation statistics, major unanticipated instabilities, and the emergence of complex networks of interacting agents. However, apart from a few exceptions (e.g. de Vries, 1998, Roorda et al, 2008), the bottom-up approach has not yet yielded macroeconomic models that can be usefully applied for policy advice, particularly with respect to climate change. For lack of an alternative, most integrated assessments of climate change have accordingly been carried out using available general equilibrium models, although the limitations of these models - in particular, the inability to capture the technological-change and adaptation processes central to the transition from a fossil-based to a carbon-free global economy - are well known (cf. Barker, 2008).

This is undoubtedly one of the reasons that the impact on climate policy of the IPCC Working Groups 2 and 3, on the impacts, adaptation and mitigation of climate change, has been much weaker than that of the 1st Working Group, on the Science of Climate Change. While the successive reports of IPCC WG 1 have finally convinced the public and policymakers that climate change is not "the world's largest hoax", policymakers have received little explicit advice from the scientific community as to the most effective policies for avoiding dangerous climate change (in contrast to the intense lobbying activities of special interest groups).

Thus, the strongest and arguably most influential report on climate policy to date, the Stern report (Stern, 2006), was based on independent economic assessments parallel to the more diffuse IPCC 2007, WG 2 and 3 reports (which were available at that time in draft form). This has led to criticisms by other economists, who questioned some of the basic tenets of the economic analysis.¹ Much of the debate has revolved around a single issue: the "correct value" of the intertemporal discount rate in evaluating the costs and benefits of climate change policies. In fact, this is a typical non-issue that arises only if one fails to use a multi-actor description of the macroeconomic system. From a multi-actor perspective, it is undisputed that different actors legitimately apply different discount rates. Thus private investors, seeking

¹To overcome the lack of international legitimacy of such reports, it has been proposed that an additional UN advisory body be created, as part of or to augment IPCC, that interacts closely with policymakers on a continuous basis, as opposed to the six-yearly reviews of IPCC (Hasselmann and Barker, 2008).

short-term returns on capital, apply high discount rates, while governments, responsible for the long-term interests of society, work with much lower or zero discount rates, as assumed by Stern.²

As an example of an attempt to bridge the gap between bottom-up and top-down multi-agent models, an overview is given in the following sections of a Multi-Actor Dynamic Integrated Assessment Model System (MADIAMS) currently in development (Hasselmann *et al*, 2008) that strives to capture both the salient features of economic variability and structural adjustment problems on the short to medium term and the longer term technological transformation processes relevant for the transition to a global carbon-free socio-economic system. MADIAMS represents an extension to a model hierarchy of a first model version MADIAM originally developed by Weber et al (2005).

3 General Structure of MADIAMS

The Multi-Actor Dynamic Integrated Assessment Model System (MADIAMS) combines a traditional macroeconomic model representation in terms of a standard state vector $\mathbf{x} = (x_j)$ of aggregated economic variables with a dynamical representation of the evolution of the system that depends on the actions of a small number of representative agents. We denote these as "actors", however, rather than "agents", to emphasize that, in contrast to the more general concept of an agent, as defined, for example, in Tesfatsion (2006), our agents are restricted to humans, rather than representing arbitrary distinct objects, such as an economic asset, that interact in some well-defined way with other distinct objects. Thus instead of representing the system as an ensemble of distinct interacting agents, in the spirit of object-oriented programming, we retain the traditional concept of an aggregated macroeconomic state vector \mathbf{x} whose components can, but need not, be assigned to individual actors, with associated dynamic evolution equations that depend on the actor control variables $\mathbf{z} = (z_j)$.

²Even the same actor will apply different discount rates in evaluating private and public components of utility. Thus Bill Gates applied different discount rates in building Microsoft than in the creation of the Bill and Melinda Gates foundation.

The evolution of the system is accordingly described by a set of coupled differential equations

$$\frac{d\mathbf{x}}{dt} = \mathbf{F}(\mathbf{x}, \mathbf{z}) \quad (1)$$

in which the individual control variables $z_j(t)$ are functions of the present and past values of the state vector and other control variables. The control algorithms can represent either the strategy decisions of individual actors (for example, with respect to the investment decisions of firms) or the outcome of negotiations between different actors (for example, in the determination of wage levels).

In contrast to most multi-agent models, our model is based on only a small number of actors. These are defined in close correspondence to the representative actors widely invoked in the classical economic literature. We regard this as the simplest and most direct way of translating the rich diversity of classical macroeconomic concepts into a simulation framework enabling a conceptual clarification and quantification of the underlying behavioral hypotheses. By circumventing the mathematical hindrances of a formal analytical approach, numerical simulations thereby focus directly on the central issue: the identification of the key actors and their behavioral patterns that are postulated to determine the dynamics of the macroeconomic system.

The representative-actor approach is nevertheless often criticized as being unable to capture the complexity of the multi-agent interactions that ultimately determine the emergent dynamics of the macroeconomic system. We attempt to overcome the limitations inherent in any system reduction approach by the standard method of parametrization. In state-of-the-art global climate models, interactions on scales smaller than the grid resolution of the numerical model, such as horizontal and vertical transports by sub-synoptic weather systems and small-scale turbulence, are routinely parametrized in terms of the explicitly resolved larger scales. The parametrizations are based on heuristic concepts on the impact of sub-resolution scale processes on the the large-scale system, which are then tested against data and specially designed higher-resolution numerical experiments. In the analagous present case, we parametrize the impact of the non-resolved multi-agent interactions by invoking the heuristic mental models of classical macroeconomic theories, which can be similarly tested against data and through special numerical experiments with a larger number of agents.

3.1 Human capital as driver of economic growth

The traditional approach to economic growth theory is to regard the net macroeconomic production Y as a function of two basic production factors, the deployed capital K_e and employed labor L_e . In addition, Y is assumed to depend on a technology parameter H , which is either prescribed exogeneously or, in more recent investigations, treated as an additional endogenous variable, normally denoted as "human capital". Human capital is represented in MADIAMS as an aggregate economic stock variable that encompasses all indirect components contributing to production, such as education, training, technology, and social capital factors such as institutions and cultural norms. We shall identify H with productivity by setting $Y = \mu H$, where μ is a proportionality constant. The third classical production factor, natural resources (land, fossil fuels, etc) is not considered in the lowest model level of MADIAMS, but is included in higher levels.

In contrast to the traditional treatment of H as an augmental parameter of the production function, we invert the role of the variables K_e , L_e , H by regarding H as the central driver of economic growth (as argued persuasively already by Adam Smith, 1776). Consistent with this view we assume that the level of technology and labor productivity H determines both the amount of physical capital $k_e = K_e/L_e$ required per employed labor and the amount of employed labor required to produce a unit of output. Thus both K_e and L_e are determined simultaneously by H , implying that – in contrast to the normal form of the production function – employed labor and capital are non-substitutable. The assumption that K_e and L_e are dependent variables was originally introduced by Leontief (1941), but led at that time to difficulties, since the governing dependence on technology was not explicitly considered. The basic Leontief assumption is simply that for a given level of technology, it is not economical to replace the best available technology by a less efficient technology that requires, for example, less physical capital but more labor to produce a given unit of output. Thus, no substitution takes place.

For a growing economy, the available physical capital K and employable labor L will not necessarily evolve in accordance with the Leontief ratio. Thus, depending on the mismatch, either the available capital K must partly idled, $K_e < K$, or the available work force L will be partly unemployed, $L_e < L$.³

³This *structural* under-deployment of one of the two production factors is indepen-

The actor strategies will normally attempt to minimize the mismatch, but in an evolving system with finite adjustment rates, some level of structural under-deployment is unavoidable.

3.2 Units

To express these relations in quantitative terms, units must be introduced. We distinguish between two kinds of units: physical units and monetary units. Physical units refer to the different outputs of production (buildings, machines, education, food, clothing, etc.) without reference to the monetary value of the outputs. At the lowest model level, we consider three production outputs: physical capital K , human capital H and consumer goods and services G (referred to in the following simply as consumer goods). Further differentiation within these three basic output categories is introduced in higher model levels.

In contrast to the unique monetary unit, the physical units as defined above are clearly highly heterogeneous and cannot be applied directly to quantify the integrated production output, or even the output of individual sectors. However, the separate physical units can be projected onto a single unit *goods* by noting (as pointed out by many classical economists) that all output is ultimately the result of human labor. It can therefore be measured in units of human labor hours τ . Since labor productivity changes with time, however, the unit *goods* must be first defined at some fixed reference time t_0 . It can then be calibrated at later times t by the standard device of introducing a suitable consumer-goods basket whose "intrinsic value" is hoped (or, from a formal viewpoint, simply defined) to be time independent. But instead of using the consumer-goods basket concept in the traditional manner to measure inflation in monetary units, it is applied here to measure changes in labor productivity, which can be translated into a calibration of the *goods* unit. Thus, if a time-independent constant *goods* value is assigned to the consumer goods basket, the net *goods* value of an output sector s at time t is defined as $\tau_s(\tau_{b0}/\tau_b)$, where τ_s is the human labor hours needed to produce the output of sector s at time t , and τ_b, τ_{b0} are the corresponding human labor hours

dent of the *cyclical* under-deployment of both factors, discussed later, due to instabilities associated with actor behaviour.

needed to produce the consumer-goods basket at time t and t_0 , respectively. In applying the same calibration update method to all production sectors, and not only to the consumer goods sector in which the consumer-goods basket was defined, we have assumed that the same change in labor productivity holds for all three production sectors. This is clearly a questionable assumption, but one which we believe does not affect the general structural relations that we are concerned with in the present overview.

Our model is scale invariant. Thus, by expressing all relations in terms of variables normalized with respect to the available labor L , the variable L disappears from the evolution equations. It enters only indirectly as a (not necessarily constant) time-rate parameter $(dL/dt)/L$ in the case of a changing pool of available labor $L(t)$.

We denote aggregate values by upper-case letters and normalized variables divided by the available labor L by lower-case letters. A subscript e is added to variables for the actually employed labor and physical/human capital to distinguish these from the available labor and physical/human capital, since the former may be smaller due to a mismatch in the Leontief ratio (or within a business cycle). However, all variables remain normalized with respect to the available labor pool L .

Empirically, the historical data yield a closely linear relation between labor productivity y and the physical capital requirements k_e per employed labor (one of the basic so-called stylized facts of macroeconomics, cf. Maddison, 1982, 1995). Thus, noting that we have already related aggregate human capital H to aggregate production Y via a constant μ , we obtain in the case of matched physical and human capital (full employment of labor and physical and human capital, $L_e = L$, $k_e = k$, $h_e = h$):

$$y = \nu k = \mu h, \quad \nu = \text{const}, \quad \mu = \text{const} \quad (2)$$

In the non-matched cases, the corresponding relations become, for idle physical capital ($\nu k > \mu h$):

$$y = \nu k_e = \mu h, \quad \text{with} \quad k_e = \mu h / \nu < k; \quad (3)$$

and for unemployed labor ($\nu k < \mu h$):

$$y = \nu k = \mu h_e, \quad \text{with} \quad h_e = \nu k / \mu < h \quad (4)$$

4 Model levels

MADIAMS is subdivided into three basic model levels M1, M2 and M3 (Figure 1). The lowest-level model M1 describes a macroeconomic system governed by the actions of firms, households and banks, but without governments. These are introduced in the intermediate model level M2, while the third model level M3 represents a full integrated assessment model including also the climate system. Further differentiations into sub-models M1a, b,..., M2a,b,..., M3a,b,.. refer to the number and type of sectors, regions, actors, etc.

The lowest model level M1 is similar to the core economic model of the original MADIAM model (Weber *et al*, 2005), but with an important difference: instead of assuming that the supply and demand of consumer goods equilibrate on the slow time scales of the model, all three production outputs, including consumer goods, are treated in M1 as non-equilibrated dynamic stock variables. This enables a combined investigation of both the slow growth of physical and human capital and the more rapid variations induced by imbalances in the supply and demand of consumer goods. The model is thereby able to simulate business cycles, recessions and the impact of the counter-acting stabilization policies of a central bank, a necessary tool for assessing the combined impact of long-term climate mitigation policies and short-term monetary stabilization policies.

The inclusion of governments in model level M2 enables the consideration of fiscal policy in addition to monetary policy, thereby illuminating the different assumptions on actor behavior underlying the long-standing debate between neo-Keynsians and monetarists on the relative effectiveness of government stimulated investments and central bank interest rates in stabilizing economic growth. The main focus in model level 2, however, is on government climate policies in the form of carbon taxes, tradeable emission permits, subsidies, or direct emission regulations.

Model level M3, finally, completes the integrated assessment model hierarchy by incorporating the climate sub-module NICCS (Nonlinear Impulse response coupled Climate-Carbon-cycle System) of the original MADIAM model. NICCS computes the greenhouse gas forcing by CO₂ emissions and the resultant climate change in the form of regionally dependent changes in

near-surface temperature and sea-level (represented by the dominant first empirical orthogonal functions for each of the two fields). The back-interaction of the computed climate change on the macroeconomic system is expressed in terms of simple aggregate cost functions. Not considered in the original MADIAM version of the model is the interaction between different economic regions via trade, an important extension that still needs to be implemented.

5 Simulation examples

The following simulation examples illustrate two general points: 1) long-standing verbal debates on the role of actor behavior in determining macroeconomic dynamics can be readily translated into very simple system dynamics models, and 2) even for very simple models it is often difficult to predict *a priori* the outcome of assumed actor behavior, although this can usually be readily reconstructed *a posteriori*. Thus, system dynamics represent primarily an important learning and expository tool.

Figure ?? shows a Vensim sketch of the main routine that computes the goods stocks and flows of the lowest level MADIAMS model M1. Stocks are represented as boxes, flows (rates of change) as crosses, sources and sinks as clouds, and functional dependencies as arrows. (The "dummy" variable *kdum* is used to model the learning-by-doing effect of increased human capital through investments in physical capital.) Not shown are further sketches of various sub-routines representing money flows and the actor algorithms (input variables from other sub-routines are indicated by cornered parentheses). The three actors of the model pursue different goals: firms strive to maximize profits, households to maximize consumption, while the central bank strives to maintain a balanced money supply and counter possible instabilities.

Figure ?? shows two very different growth paths resulting from two equally plausible hypotheses of the reponse of firms to a changing demand for consumer goods. This was prescribed in both simulations by the negotiated wage levels and the fraction of household income spent on consumption rather than saving. Other model settings were also identical, and actor behavior leading to instabilities (see below) was excluded.

In simulation S , firms strive to maintain a chosen target level g_{tar} of the consumer-goods *stock* (set proportional to k , as a proxy for the size of the economy) by adjusting the investments in the consumer goods production sector at a rate proportional to $\max(0, g_{tar} - g)$. In simulation F , in contrast, the adjustment rate was set proportional to the difference between the *flows* into and out of the goods stock, i.e. by the difference between the production and consumption of consumer goods. The difference between the growth paths is seen not only in the time scales (which can be adjusted by the choice of rate coefficients), but, more importantly, in the growth structure: simulation S emphasizes short term consumption over profits and long-term growth, while the reverse applies for simulation F (Figure ??). The structural differences in the growth paths is seen most clearly in the supply response rates: the disequilibrium values R_S in the consumer goods *stocks* and R_S in the consumer-goods *flows* (Figure ??). Which of the two hypotheses is closer to reality must be decided by a combination of stakeholder interviews and comparisons with data, which is beyond the scope of the present paper; the relevant point here is the strong dependency on elementary actor behavior, which can not be captured in a traditional actor-independent equilibrium-growth model.

It is important in an aggregated multi-actor model to distinguish between the optimal strategies of the hypothetical single aggregate actor of the model and the real aggregate actor, representing an ensemble of individual actors. A hypothetical single aggregate firm, for example, will strive to optimize aggregate intertemporally discounted profits. This normally leads to growth paths, such as the paths S and F , in which physical and human capital are closely matched, in accordance with eq.(2). An individual firm, on the other hand, will find it more profitable to invest more strongly in human capital, as this reduces firm costs by reducing the number of employed labor for a given output (see Weber *et al.*, 2005, for a discussion of the resultant structural unemployment). For the hypothetical single aggregate firm, this is not an attractive strategy, as the effect is neutralized by the negative feedback of the reduced aggregate purchasing power of households, which leads to a commensurate decrease in the aggregate income of the firm (the trap of Say's law). But the real individual firm is not concerned with aggregate conditions. Thus the actions of the real aggregate firm, defined as the aggregate sum of the actions of individual firms, will generally differ from the actions of the hypothetical single aggregate firm, which is concerned only with aggregate

values.

The discrepancy between the strategies of the hypothetical single aggregate actor and the strategies of the real aggregate actor is the origin of most macroeconomic instabilities. Figure ?? shows as example a business cycle (to be regarded as superimposed on the longer term background growth of Figure ??) resulting from the actions of individual firms and households in model M1. These lead to unstable feedbacks that a rational hypothetical aggregate actor would not engage in. The left panel shows the slow-down in production (*dely*) by firms in response to a decrease in household consumption (*delcons*) (triggered, for example, by some random external event). The reduced production, associated with lay-offs, etc, induces a further reduction in consumer confidence and consumption. This positive feedback loop by itself (top two boxes) would produce an unstable exponential collapse of production and consumption (a recession). However, the instability is converted into a periodic cycle through a stabilizing negative feedback loop (bottom two boxes), representing the willingness of firms to employ more labor once wages have been sufficiently depressed by the reduced employment level.

There exist many alternative explanations of business cycles, together with numerous associated proposals for their control through appropriate monetary or fiscal policies (cf. Lucas, 1987, Howitt, 2006). The present example underlines the comments made in the introduction to this section: the basic macroeconomic hypotheses can be readily expressed in appropriate system dynamics terms, but the outcome of the model simulations, even for the simple model shown in Figure ??, is normally strongly dependent on the details of the hypothesized actor behaviour and difficult to foresee. Thus, in the present example, the cycles can have very different amplitudes and periods, or can revert to exponential collapse, depending on the values of the feedback coefficients (*fac1*, *fac2*, *fac2a*, *fac3*) characterizing the inter-actor coupling. Nevertheless, the translation of the assumed actor behavior into mathematical terms, with associated computer simulations, remains a necessary first step for a meaningful assessment of macroeconomic stability policies.

We leave a more detailed discussion of business cycles, including stabilizing monetary policies (by the central bank in M1) and fiscal policies (by governments in model level M2) to a later investigation. Similarly, we refer to Weber *et al*, 2005 for an application of the comprehensive third level model MA-

DIAM to assess the impact of government climate policies on climate change, economic growth, employment levels, technological change, fossil fuel use, etc. Also discussed in Weber *et al* was the role of household preferences for climate-friendly goods in promoting investments in low-carbon technologies.

Not considered in MADIAM (or M3a) were further actors engaged in the processes of scientific information creation and dissemination and in policy formation and implementation. Model M3b (Figure ??) represents an attempt to capture these processes in a rudimentary manner using a strongly reduced but appropriately augmented version of M3a. The model consists of a complex delay chain, beginning with the first effective presentation of scientific knowledge through the creation of IPCC in 1990, which is then immediately contaminated by climate skeptics, and disseminated, after the addition of further noise, by the media. This stimulates, nevertheless, first climate policy concepts, which are then expanded and implemented after further delays, resulting in the necessary technological investments (Fig 7a) to reduce emissions (Fig 7b). A distinction is made in Fig. 7a between investments in low-fruits renewable technologies (wind and hydro power, biofuels,...) that become competitive through a carbon tax or a cap-and-trade system ("stick" policies) and high-fruits technologies (concentrated solar power) that require subsidies ("carrot" policies) to penetrate the market. The final global warming and associated economic growth paths for this particular (optimistic) scenario are shown in Figures ??d, ??c. Also shown in Figures ??b,c,d are the corresponding curves for the IPCC business as usual (BAU) scenario.

The simulations highlight the delays incurred through the cascade from information transfer to policy implementation, while confirming the previous results of Weber *et al* (2005) and the Stern report (Stern, 2007) that dangerous climate change (generally defined as a 2°C warming above the pre-industrial level) can be avoided at an affordable long-term cost of about 1% (-1% to maximally 4%) of GDP.

6 Conclusions

An effective response to the challenge of global climate change requires major changes in many areas of human behavior, from consumer preferences to the

investment decisions of firms, from regulations on communal and national levels to international agreements on global climate policies. If science is to contribute to the required behavioral transformation through quantitative analyses, a "mathematics of social entities" is clearly needed. However, it is less clear how one can best translate the mental concepts of human behavior developed by social scientists into meaningful mathematical models.

I have argued for a modest, iterative approach: the development of a hierarchy of relatively simple models, beginning with highly idealized models, and adding further details and modifications at higher model levels only after the lowest levels have survived appropriate plausibility tests. The limits of acceptable complexity will normally be attained rather rapidly through the restrictions on available data.

More important than formal mathematical analysis for the translation of the concepts of "soft" sciences into the quantitative methods of "hard" science is the application of computer simulations. In order to communicate the results of such simulations, however, a common language is needed. Graphical software presentations are generally found to be more effective in communicating between different disciplines than mathematical code.

In the specific case of climate change, the role of human behavior, although acknowledged verbally, has been largely ignored in quantitative assessments of the impacts of climate change and climate change policies. This is due to the application of traditional macroeconomic general equilibrium models. By invoking Adam Smith's famous "invisible hand" that magically brings about the assumed equilibrium, this ignores the important role of individual human actors, whose conflicting goals and strategies determine the dynamic evolution of the global socio-economic system that climate policies attempt to guide. The limitations of the general equilibrium approximation in describing dynamic evolution process are generally recognized, and many alternative approaches based on multi-agent dynamics have been proposed. However, these have been mostly applied to microeconomic processes; there exist relatively few applications of agent-based models to the integrated assessment of climate change.

In view of the high priority of climate change on the political agenda, the development of multi-agent macroeconomic models for the integrated assessment of climate change is urgently needed. It is hoped that the examples

selected here from the ongoing development of the MADIAMS model hierarchy will stimulate further investigations in this direction.

References

1. Axtell, R.L., Multi-agent Systems Macro: A Prospectus, in Post Walrasian macroeconomics, D. Colander (ed), 203-220, Cambridge University Press, 2006
2. Barker, T., The Economics of Avoiding Dangerous Climate Change, An editorial essay. *Climatic Change*, **89**,, 2008
3. Beinhocker, E. The Origin of Wealth, Harvard Business School Press, 2006
4. Colander, D. Post Walrasian Macroeconomics, Cambridge University Press, 2006
5. de Vries, B., SUSCLIME: a simulation/game on population and development in a climate-constrained world, *Simulation and Development*, **29**, 216-237, 1998
6. Epstein, J.M and Axtell, R., *Growing Artificial Societies*, Washington, D.C., Brookings Institution Press, Cambridge, MA: MIT Press, 1996
7. Hasselmann, K. and T. Barker, The Stern Review and the IPCC fourth assessment report: implications for the interaction between policymakers and climate experts. An editorial essay. *Climatic Change*, **89**, 219-229, 2008
8. Hasselmann, K., D.Kovalevsky and C. Jaeger, A system dynamics approach to the integrated assessment of climate change, in preparation, 2008
9. Howitt, P., Monetary Policy and the Limits of Economic Knowledge, in Post Walrasian macroeconomics, D. Colander (ed), 175-202, Cambridge University Press, 2006

10. IPCC, Intergovernmental Panel on Climate Change, Fourth Assessment Report, Working Groups 1,2 and 3 (three volumes), Cambridge University Presse, 2007
11. Hooss G., R. Voss, K. Hasselmann, E. Maier-Reimer and F. Joos, 2001, A nonlinear impulse response model of the coupled carbon cycle-climate (NICCS), *Climate Dynamics*, **18**, 189-202.
12. Leontief, W., *The Structure of the American Economy: 1919-1929*, Harvard University Press, Cambridge, MA, 1941
13. Lucas, R.E. Jr., *Models of Business Cycles*, Oxford; Blackwell, 1987
14. Maddison, A., *Phases of Capitalist Development*, Oxford University Press, 1982
15. Maddison, A., *Monitoring the World Economy 1820-1992*, OECD Publications, Paris, 1995
16. Nelson, R.R. and S.G. Winter, *An Evolutionary Theory of Economic Change*, Cambridge, MA, Belknap Press of Harvard University Press, 1982
17. Roorda, C., B. de Vries and K. Lindgren, *SUSCLIME: Exploring Strategies for Resource Depletion and Climate Change*, draft document, 2008
18. Smith, A, *The wealth of nations*, 1776, Reprint edition, New York, modern library, 1994
19. Sterman, J.D. *Business Dynamics*, New York, McGraw-Hill, 2000
20. Stern, N., *The economics of climate change. The Stern Review*, 2007
21. Tesfatsion, L. Computational modeling and macroeconomics, in *Post Walrasian macroeconomics*, D. Colander (ed), 175-202, Cambridge University Press, 2006
22. Weber, M., V. Barth and K. Hasselmann, *A Multi-Actor Dynamic Integrated Assessment Model (MADIAM) of Induced Technological Change and Sustainable Economic Growth*, *Ecological Economics*, **54**, 306-327, 2005

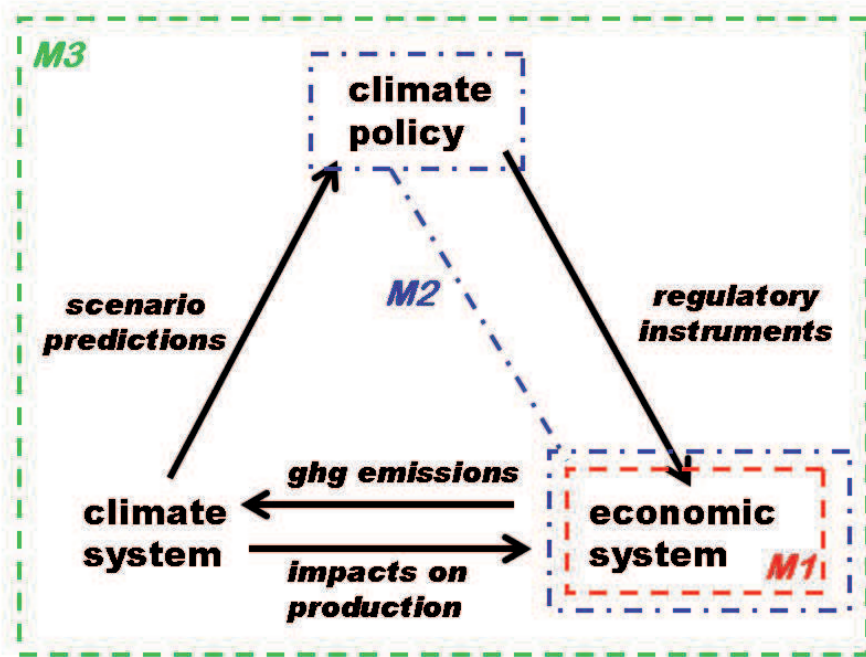

Figure 1: *Interrelation of the three model levels M1, M2 and M3 of the coupled climate socio-economic model hierarchy MADIAMS.*

Main routine: production outputs in physical goods units

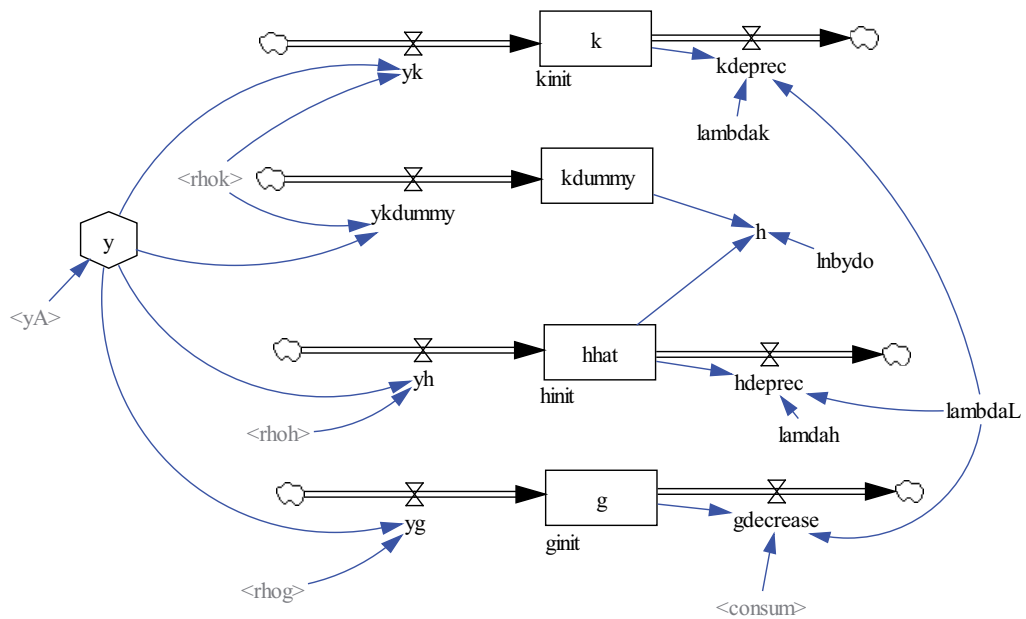

Figure 2: *Flow diagram for production of physical and human capital (k, h) and consumer goods and services (g) for the lowest level model M1 of MADIAMS*

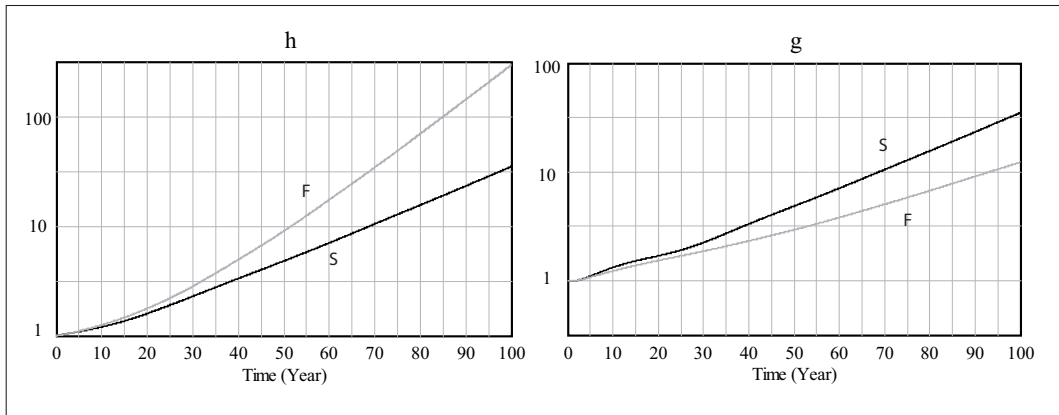

Figure 3: *Growth paths of human capital h (left panel) and physical capital k (right panel) for two different firm supply strategies in response to variable consumer goods demand: (i) S , black lines, (maintainence of target consumer goods stock, and (ii) F , blue lines, flow balance between consumer goods production and demand)*

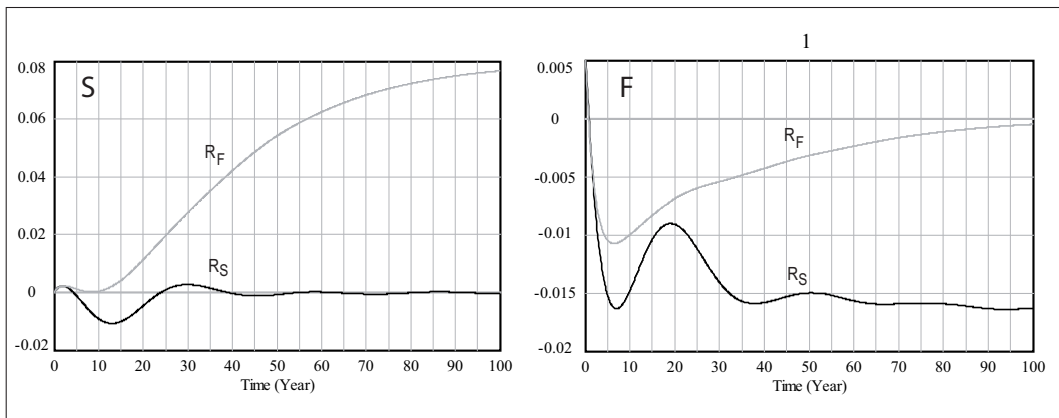

Figure 4: *Feedback factors R_S (black lines) and R_F (blue lines) computed for firm supply strategies S and F in response to variable consumer goods demand. Left panel: Simulation S in which the feedback factor R_S was applied; right panel: corresponding simulation F in which the feedback factor R_F was applied.*

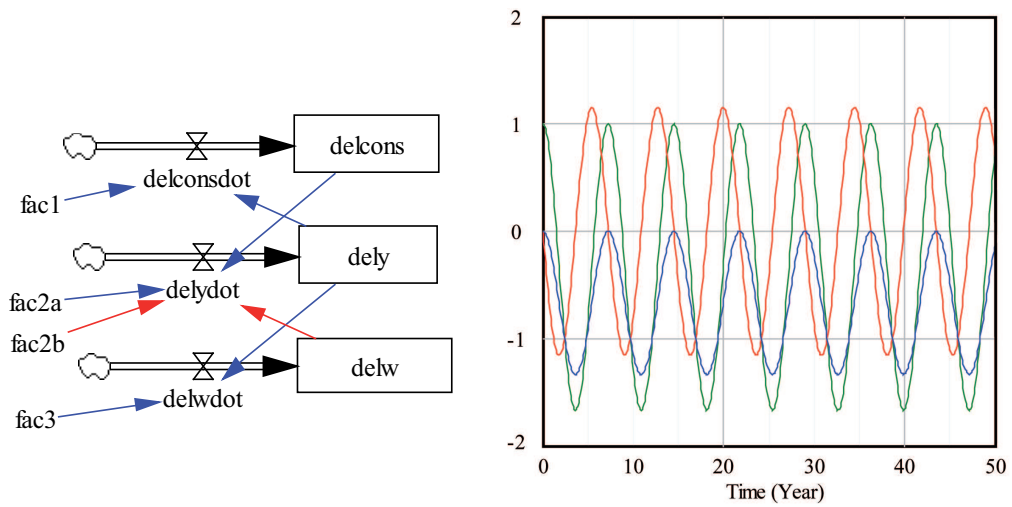

Figure 5: *Left panel: Business cycle model of feedbacks between modifications of consumption (delcons), production (dely) and wage levels (delw). Blue lines represent positive feedbacks driving exponential instabilities, red lines negative feedbacks leading to oscillations. The variables fac1, ..., fac3 denote feedback coefficients which control whether the instabilities lead to oscillations or exponential decay or growth. Right panel: a resulting oscillation, in normalized units (delcons: blue; dely: red; delw: green)*

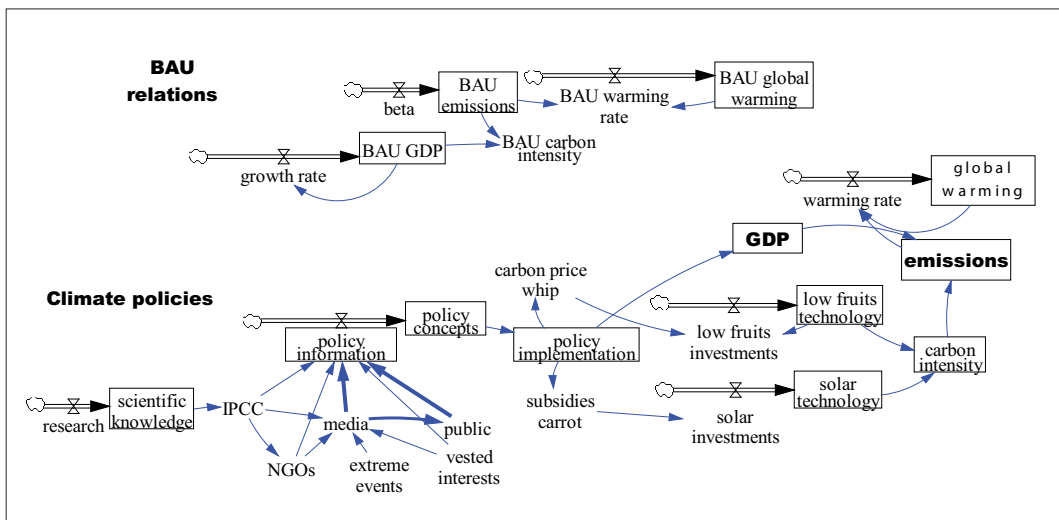

Figure 6: *Information flow rates and political and technological responses (represented by integrating box variables) that characterize the delay chain from the creation of scientific knowledge to the final reduction of global warming. Top sketch: no climate policy (business as usual, BAU); bottom sketch: with climate policy*

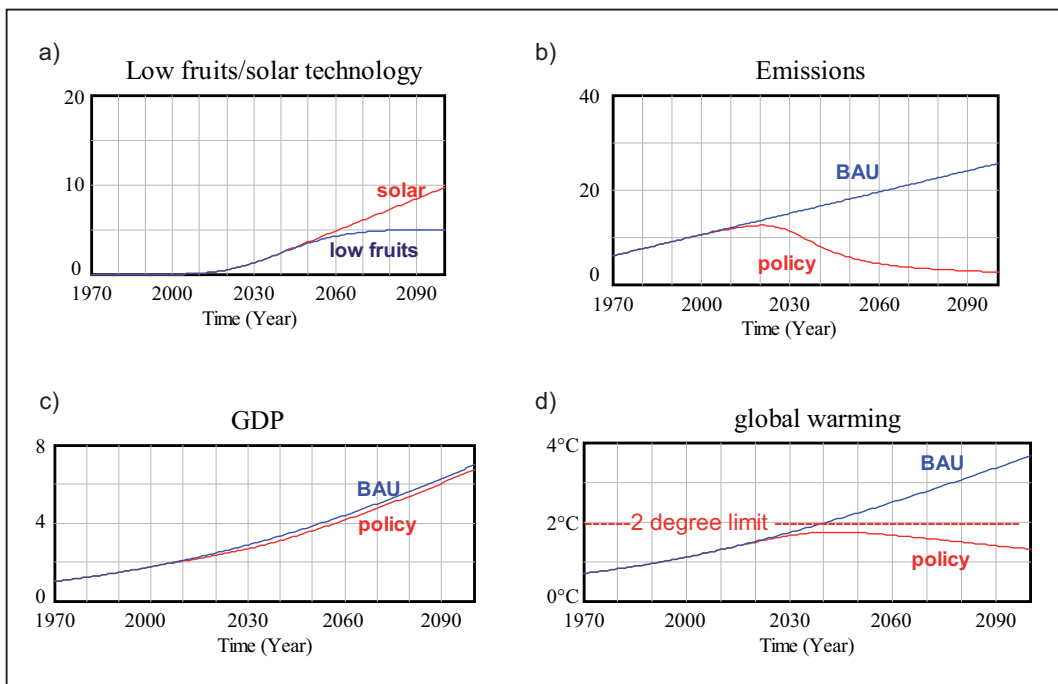

Figure 7: Resultant evolution of low-fruits and high-fruits (solar) technologies (panel a), CO_2 emissions (panel b), global warming (panel d) and GDP (panel c) for the information-to-policy-implementation delay chain of Figure 6.